

BY MAIL ONLY

July 13, 2017

Leonard and Josephine Lausen

EMBER RESOURCES INC.

APPLICATIONS NO. 121526

STATEMENTS OF CONCERN NO. 30599

Dear Leonard and Josephine Lausen:

You are receiving this letter because you filed a statement of concern about Application No. 121526. The Alberta Energy Regulator (AER) has reviewed your statement of concern, along with the application, the applicable requirements, and other submissions or information about the application. The AER has decided that a hearing is not necessary to consider the concerns outlined in your statement of concern.

In its review of your concerns, the AER considered the following:

- The DSA conducted on November 23, 2016, found that landscape, soils, and vegetation, including weeds and invasive species, at the sites were comparable to offsite adjacent lands. It is the professional opinion of the assessor conducting the DSA that the site meets the *2010 Reclamation Criteria for Wellsites and Associated Facilities for Cultivated Lands* (2010 Reclamation Criteria).
- The AER conducted a site inspection with a company consultant on June 15, 2017. The AER noted that the location was drilled in the winter using a minimum disturbance method where the only soils disturbance was at well center to install the cellar prior to drilling. The 2016 crop residue was consistent on and offsite and in 2017 the field was seeded to canola and the growth was similar in height, density, health and vigour on and offsite.
- Information from the site visit and the DSA demonstrates that the Site meets the *2010 Reclamation Criteria* for landscape, soils and vegetation.
- The AER understands that Mr. Lausen has indicated that, at this time, he is not requesting a hearing to consider his concerns.

- The *2010 Reclamation Criteria* are applied “to evaluate whether a site has met equivalent land capability.” Given that the site meets *2010 Reclamation Criteria*, the AER is satisfied that the site has met equivalent land capability and your concerns related to equivalent land capability have been addressed.

The AER has issued the applied-for reclamation certificate and this is your notice of that decision. A copy of the reclamation certificate is enclosed. Under the *Responsible Energy Development Act* an eligible person may file a request for a regulatory appeal on an appealable decision. Eligible persons and appealable decisions are defined in section 36 of the *Responsible Energy Development Act* and section 3.1 of the *Responsible Energy Development Act General Regulation*. If you wish to file a request for regulatory appeal, you must submit your request in the form and manner and within the timeframe required by the AER. You can find filing requirements and forms on the AER website, <http://www.aer.ca/applications-and-notices/appeals>.

inquiries 1-855-297-8311
24-hour
emergency 1-800-222-6514

If you have any questions, contact Rachel Ruddell at 403-297-8557 or e-mail rachel.ruddell@er.ca.

Sincerely,

< original signed by >

Helene de Beer
Director
Oil and Gas, Closure and Liability

Enclosure (1): Reclamation Certificate

cc: Bryce Watson, Ember Resources Inc.
AER SOC Coordinator
AER Medicine Hat Field Centre

RECLAMATION CERTIFICATE NO. 121526

This reclamation certificate is issued pursuant to section 138 of the Environmental Protection and Enhancement Act (the act), following a review of the information provided in the application. No reclamation inquiry has been held.

This certifies that the surface of the land held by Ember Resources Inc., in connection with or incidental to the activities:

Activity Type	Licence/Segment	LLD	Asset Name
	0412590	SE 1-34-22-25-W4M	EMBER 102 ENTICE 1-34-22-25

as shown outlined in yellow on the attached plan(s), complies with the conservation and reclamation requirements of Part 6 of the act.

Issued on July 13, 2017



Steve Demkiw
Designated Inspector Under the Act

Operator/Agent:
Ember Resources Inc.
800 - 400 3 Ave SW
Calgary

The AER may cancel this reclamation certificate pursuant to section 139 of the act where it is of the opinion that further work may be necessary to conserve and reclaim the above specified land to which this certificate relates.

The Responsible Energy Development Act (REDA) permits the filing of a request for a regulatory appeal by an eligible person in regards to an appealable decision as defined in section 36 of REDA. If you are eligible to file a request for a regulatory appeal and you wish to do so, you must submit your request in the form and manner and within the timeframe required by the AER. Filing requirements are set out in section 30 of the Alberta Energy Regulator Rules of Practice available on the AER website, www.aer.ca, under Rules & Directives > Acts, Regulations and Rules. Regulatory appeal requests should be e-mailed to RegulatoryAppeal@aer.ca.

Alberta Energy Regulator Suite 1000, 250 Street SW, Calgary, Alberta T2P 0R4

Plan Showing Survey of
ECA ECOG STRATHMORE 1 - 34 - 22 - 25
 Well Site
 In
L.S. 1 Sec.34 Twp.22 Rge.25 W.4 M.
 WHEATLAND COUNTY

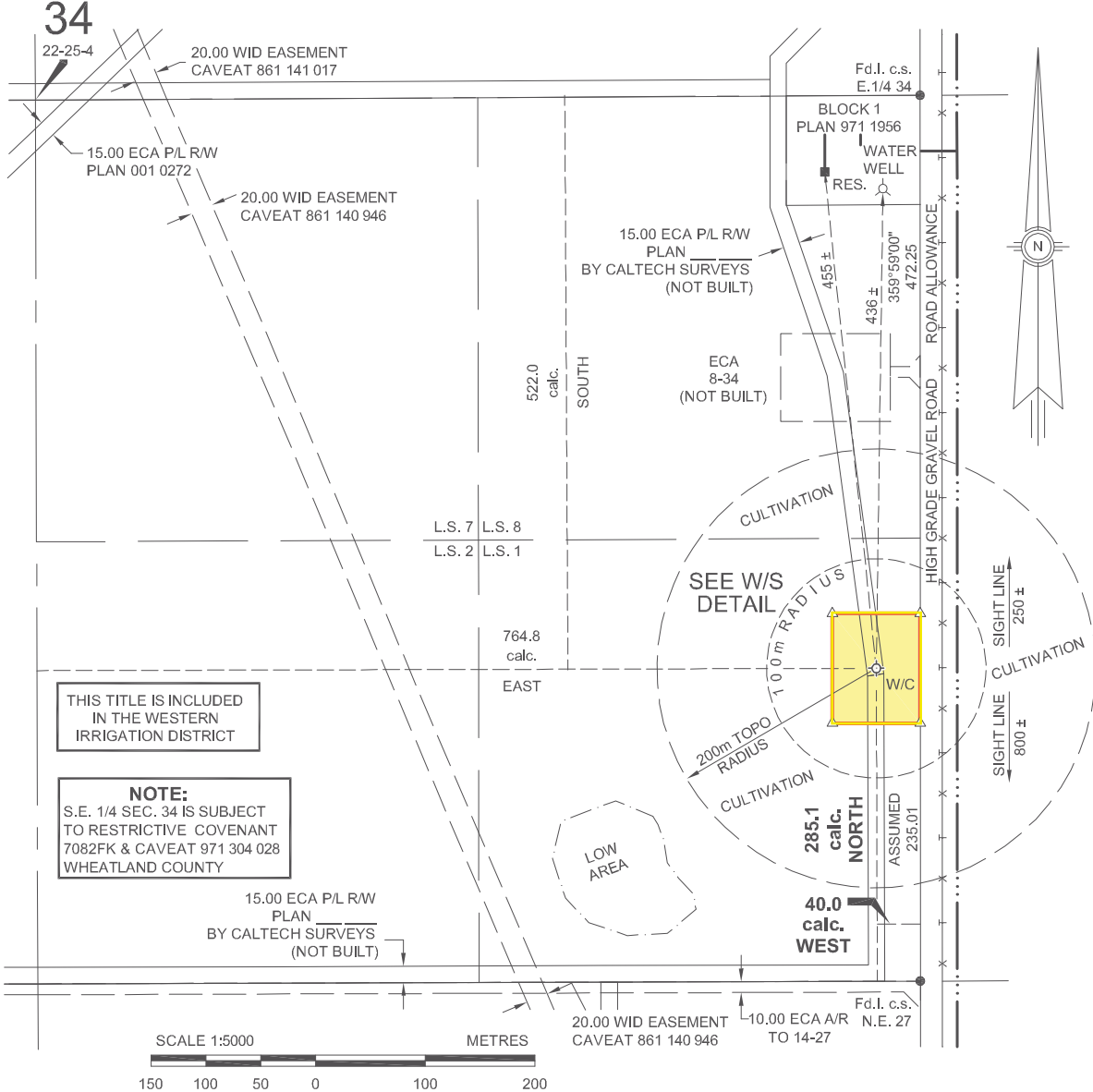

ERCBC LICENCING INFORMATION:

	YES	NO
The proposed well is at least 1.5km from the corporate limits of a city, town or village	<input checked="" type="checkbox"/>	<input type="checkbox"/>
The proposed well is at least 5.0km from a lighted airport	<input checked="" type="checkbox"/>	<input type="checkbox"/>
The proposed well is at least 1.6km from an unlighted airport	<input checked="" type="checkbox"/>	<input type="checkbox"/>
The proposed well is at least 100m from any surface improvements (BURIED GAS LINE, P/L R/W - NOT BUILT & TELUS CABLE)	<input type="checkbox"/>	<input checked="" type="checkbox"/>
The proposed well is at least 40m from any surveyed road	<input checked="" type="checkbox"/>	<input type="checkbox"/>
The proposed well is at least 100m from any water body	<input checked="" type="checkbox"/>	<input type="checkbox"/>
The proposed well is 200m from any water well	<input checked="" type="checkbox"/>	<input type="checkbox"/>
The proposed well is outside any potential coal development area	<input checked="" type="checkbox"/>	<input type="checkbox"/>

SURFACE CO-ORDINATES: 1-34
 285.1 NORTH of SOUTH } SEC. 34
 40.0 WEST of EAST }
GEOGRAPHIC CO-ORDINATES:
 LAT: 50.909699° } NAD 83
 LONG: 113.375759° } ATS Ver. MARCH 2005
UTM CO-ORDINATES:
 5 642 241.0 N. } NAD 27
 333 046.2 E. } ATS Ver. 2.6
ELEVATIONS: WELL CENTRE = 957.3
 N.W. = 957.11 N.E. = 959.00
 S.W. = 956.69 S.E. = 957.44
 DATUM: ASCM 393116
 ELEV.: 999.352

OPERATOR: ENCANA.

Angie Simpson
 Digitally signed by Angie Simpson
 DN: cn=Angie Simpson, o=CIA, ou=Encana Oil and Gas Partnership, ou=Springer, ou=Property Team, email=Angie.Simpson@Encana.com
 Reason: I agree to specified portions of this document
 Date: 2009.05.29 11:03:25 -0600

AREAS: HECTARES ACRES
 WELL SITE : 0.800 1.98

OWNER(S): LEONARD HANS LAUSEN		CALTECH JOB NO.: 06-2384-34	
JOSEPHINE MARGUERETTE LAUSEN			
AFE NO.: 09122980	FILE NO.: S436949	PROJECT NO.: STRDC19	2
06-2384W34-R2.DWG	DRN: KF	CK'D: JTZ	
	PC: JK	PAGE: 1 OF 2	
			REVISION

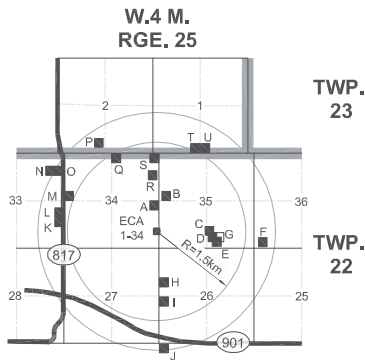

SURFACE DEVELOPMENT SKETCH

SCALE: 1:100 000

ONLY SURFACE DEVELOPMENTS WITHIN 2km OF W/C ARE SHOWN

OCCUPIED RESIDENCES SHOWN THUS: ■
 UNOCCUPIED RESIDENCES SHOWN THUS: □
 OTHER SURFACE DEVELOPMENTS SHOWN THUS: ▲
 NEAREST SURFACE DEVELOPMENT IS THE RESIDENCE

0.45km ± N. OF WELL CENTRE
 NEAREST URBAN CENTRE
 IS CARSELAND 9.1km ± S.W. OF WELL CENTRE

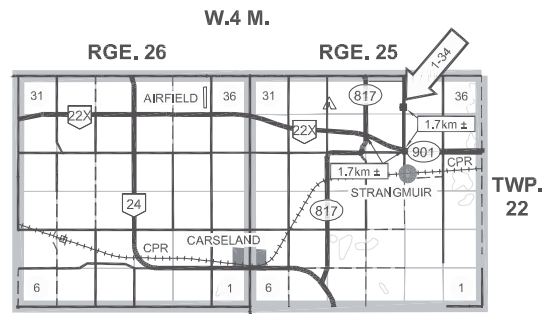

ACCESS ROUTE DETAIL

SCALE: 1:250 000

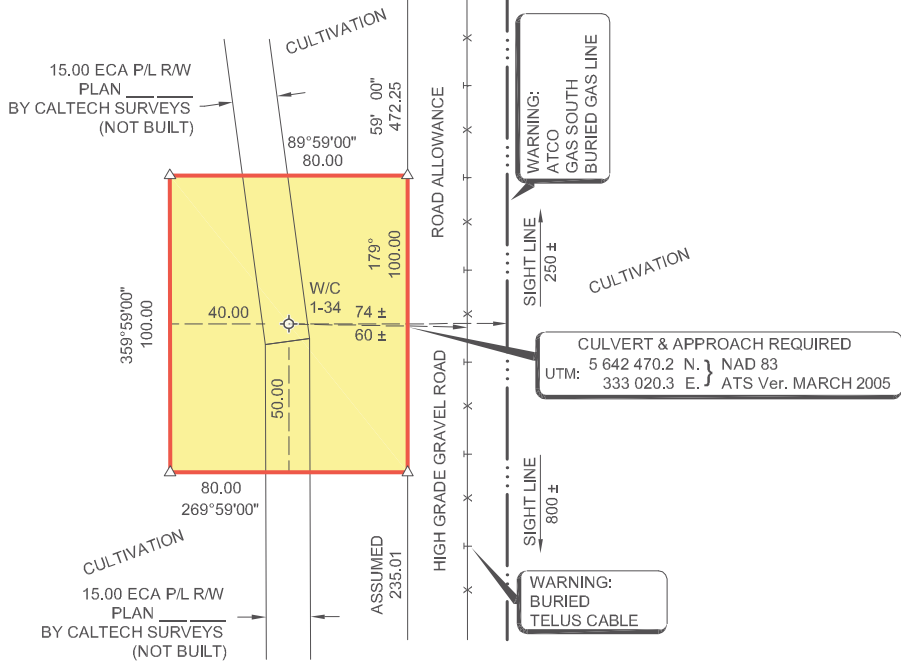

WELL SITE DETAIL

SCALE: 1:2000

I, Jeremy T. Zettel, Alberta Land Surveyor, of the City of Calgary, Alberta, certify that the survey represented by this plan is true and correct to the best of my knowledge, has been carried out in accordance with the Alberta Land Surveyors' Association Manual of Standard Practice, and the field survey was performed between the 27th day of May, 2007 and the 8th day of April, 2009.

Jeremy T. Zettel
 Date Signed 2009.04.14
 Chad Skretting Witness

CALTECH SURVEYS LTD
 Calgary (403) Ph: 263-8055 Fax: 263-8058
 Regina (306) Ph: 775-1814 Fax: 775-1818
 Unity (306) Ph: 228-4366 Fax: 228-4367



WELL CENTRE CO-ORDS

GIVEN = 325.0 N. of S. } BDY.
 50.0 W. of E. } SEC. 34

SURVEYED = 285.1 N. of S. } BDY.
 40.0 W. of E. } SEC. 34

NOTE:
 W/C MOVED DUE TO
 LANDOWNER REQUEST

LEGEND:

- Well Centre(s) shown thus: ○
- Survey monument(s) found shown thus: ●
- Survey mark(s) (Spike) planted shown thus: ▲
- Survey mark(s) (Spike) found shown thus: △
- Temporary point(s) shown thus: ✕
- Portions referred to outlined thus: —
- Distances are in metres.
- Survey completed by GPS and all measurements shown are check measured.

REV.	DATE	DESCRIPTION	BY	CK'D
0	2007.06.01	ISSUED	KF	JTZ
1	2008.04.17	UPDATED	ML	AF
2	2009.04.14	UPDATED	CAS	AF

ENCANA CORPORATION

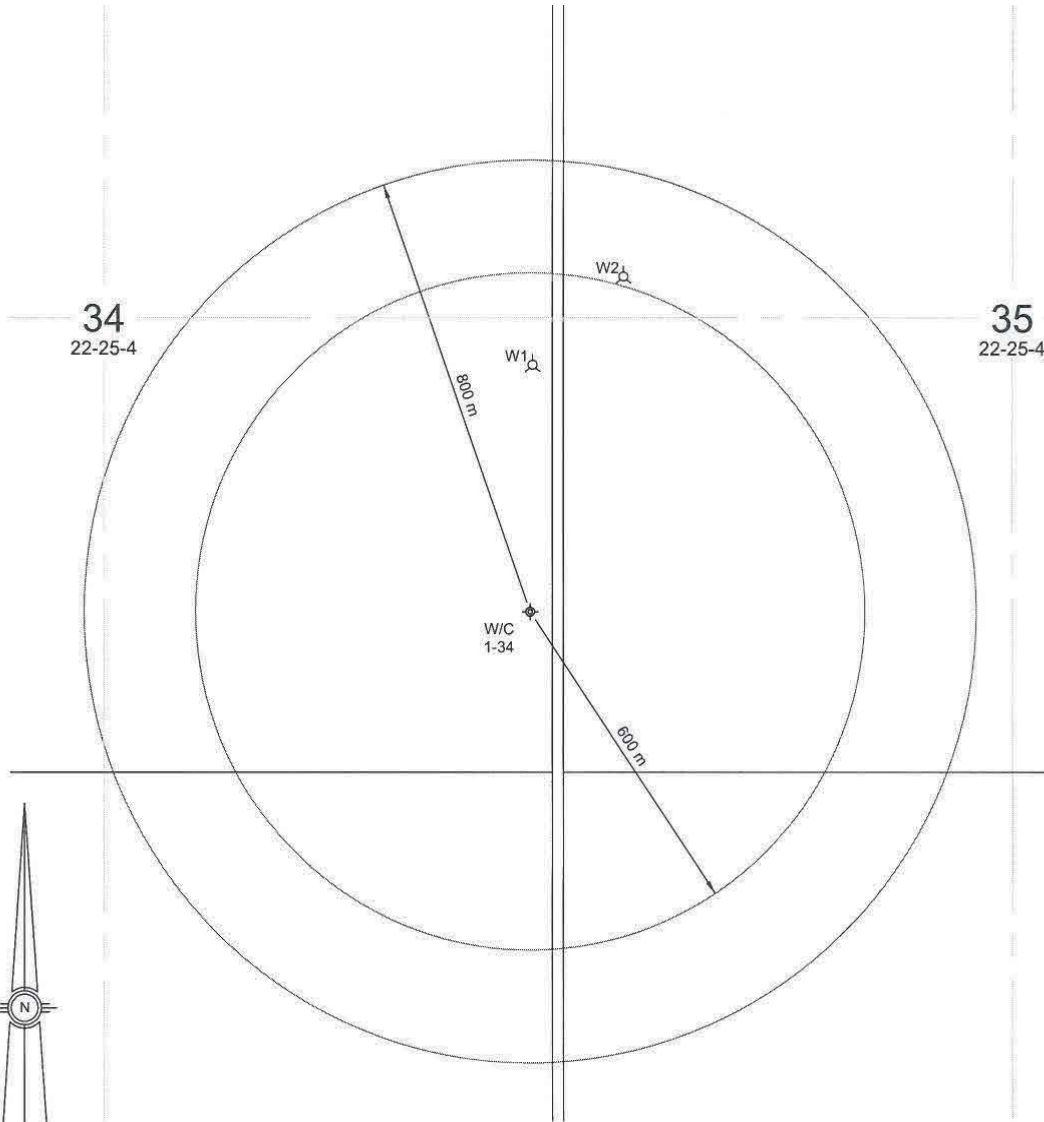

ACTIVE WATER WELLS				NAD 83 (ATS Ver March 2005) COORDINATES			
WATER WELL	WATER WELL ID	LAND LOCATION	DISTANCE TO WELL CENTRE (m)	GEOGRAPHIC		UTM	
				LAT	LONG	N (m)	E (m)
W1	-	S.E. 34	437±	50.913626	113.375693	5 642 908	332 999
W2	-	N.W. 35	617±	50.915032	113.373374	5 643 059	333 167



WATER WELL LOCATIONS IN PROXIMITY OF ECA ECOG STRATHMORE 1-34-22-25

L.S. 1 SEC. 34 TWP. 22 RGE. 25 W4M.
WHEATLAND COUNTY
ALBERTA

SCALE = 1 : 10 000

ALL DISTANCES SHOWN ARE IN METRES
 ACTIVE WATER WELLS SHOWN THUS
 INACTIVE WATER WELLS SHOWN THUS
 WATER WELLS NOT TESTED SHOWN THUS
 WATER WELL-FROM ALBERTA ENVIRONMENT
 DATABASE (NOT LOCATED) SHOWN THUS
 WELL CENTRE SHOWN THUS

CALTECH
SURVEYS LTD
 Calgary (403) Ph: 263-8055 Fax: 263-8058
 Regina (306) Ph: 775-1814 Fax: 775-1818
 Unity (306) Ph: 228-4366 Fax: 228-4367

REV.	DATE	DESCRIPTION	DRN	CK'D
0	2008.02.11	ISSUED	MLM	BP
1	2009.05.19	UPDATED	MLM	BP

AFE NO.: 8101941	CALTECH JOB NO.: 108-0507-13	1 REVISION
PROJ. FILE NO. S436949	PROJ. REF. NO.: STRDC19	
108-0507WW13-R1.DWG	DRAWN: MLM CHECKED: BP	